

HE225A,B; HE265A,B; HE365A,B Humidifiers

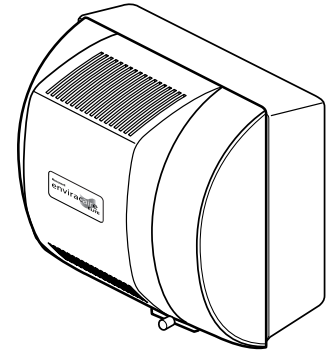
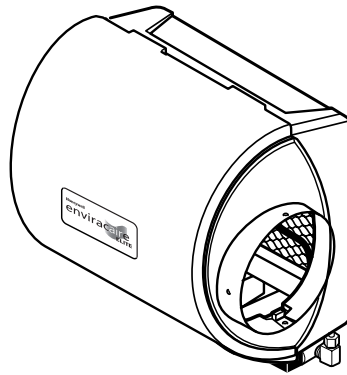
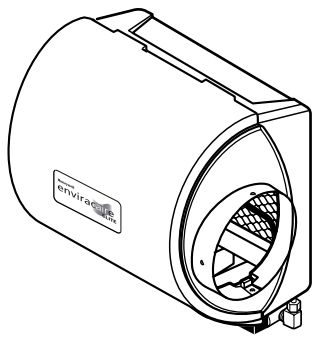

Honeywell Enviracaire Elite™ HE225A,B By-Pass Flow-Through Humidifier

Part of Honeywell's whole-house air quality system

- Antimicrobial coating on pad prevents the surface growth and migration of bacteria, mold, fungus and algae on the humidifier pad.
- Bold, new look with blue and white styling.
- System yields 12 gallons per day (46 liters per day) to humidify a large area up to 3,000 sq. ft. (280 sq. m).
- Small footprint, lightweight and reversible components allow for easy mounting on either warm air supply or cold air return of most forced air furnaces.
- Components designed for quick maintenance and service.
- Continuous flushing reduces the frequency of maintenance in a hard water installation.
- A Model includes premiere white convertible humidistat (styling similar to Chronotherm®).
- B Model includes Automatic Humidity Control with HumidiCalc+™ software.
- 5 year warranty
- Exclusive AIRWATCH™ indicator reminds customers when to change pad (optional).

Honeywell Enviracaire Elite™ HE265A,B By-Pass Flow-Through Humidifier

Part of Honeywell's whole-house air quality system

- Antimicrobial coating on pad prevents the surface growth and migration of bacteria, mold, fungus and algae on the humidifier pad.
- Bold, new look with blue and white styling.
- System yields 17 gallons per day (65 liters per day) to humidify a large area up to 4,000 sq. ft. (372 sq. m).
- Small footprint, lightweight and reversible components allow for easy mounting on either warm air supply or cold air return of most forced air furnaces.
- Components designed for quick maintenance and service.
- Continuous flushing reduces the frequency of maintenance in a hard water installation.
- A Model includes premiere white convertible humidistat (styling similar to Chronotherm®).
- B Model includes Automatic Humidity Control with HumidiCalc+™ software.
- 5 year warranty
- Exclusive AIRWATCH™ indicator reminds customers when to change pad (optional).

Honeywell Enviracaire Elite™ HE365A,B Powered Humidifier

Part of Honeywell's whole-house air quality system

- Antimicrobial coating on pad prevents the surface growth and migration of bacteria, mold, fungus and algae on the humidifier pad.
- Bold, new look with blue and white styling.
- System yields 18 gallons per day (69 liters per day) to humidify a large area up to 4,200 sq. ft. (390 sq. m).
- Small footprint allows for easy mounting on either warm air supply or cold air return of most forced air furnaces.
- Components designed for quick maintenance and service.
- Continuous flushing reduces the frequency of maintenance in a hard water installation.
- A Model includes premiere white convertible humidistat (styling similar to Chronotherm®).
- B Model includes Automatic Humidity Control with HumidiCalc+™ software.
- 5 year warranty
- Exclusive AIRWATCH™ indicator reminds customers when to change pad (optional).